

THIS DRAWING IS UNPUBLISHED. RELEASED FOR PUBLICATION .19
 © COPYRIGHT 19 BY AMP INCORPORATED. ALL RIGHTS RESERVED.

REVISIONS				DATE	DWN	APVD
P	LTR	DESCRIPTION				
A		REV PER 0G3C-0213-99	01DEC99	BH	JG	

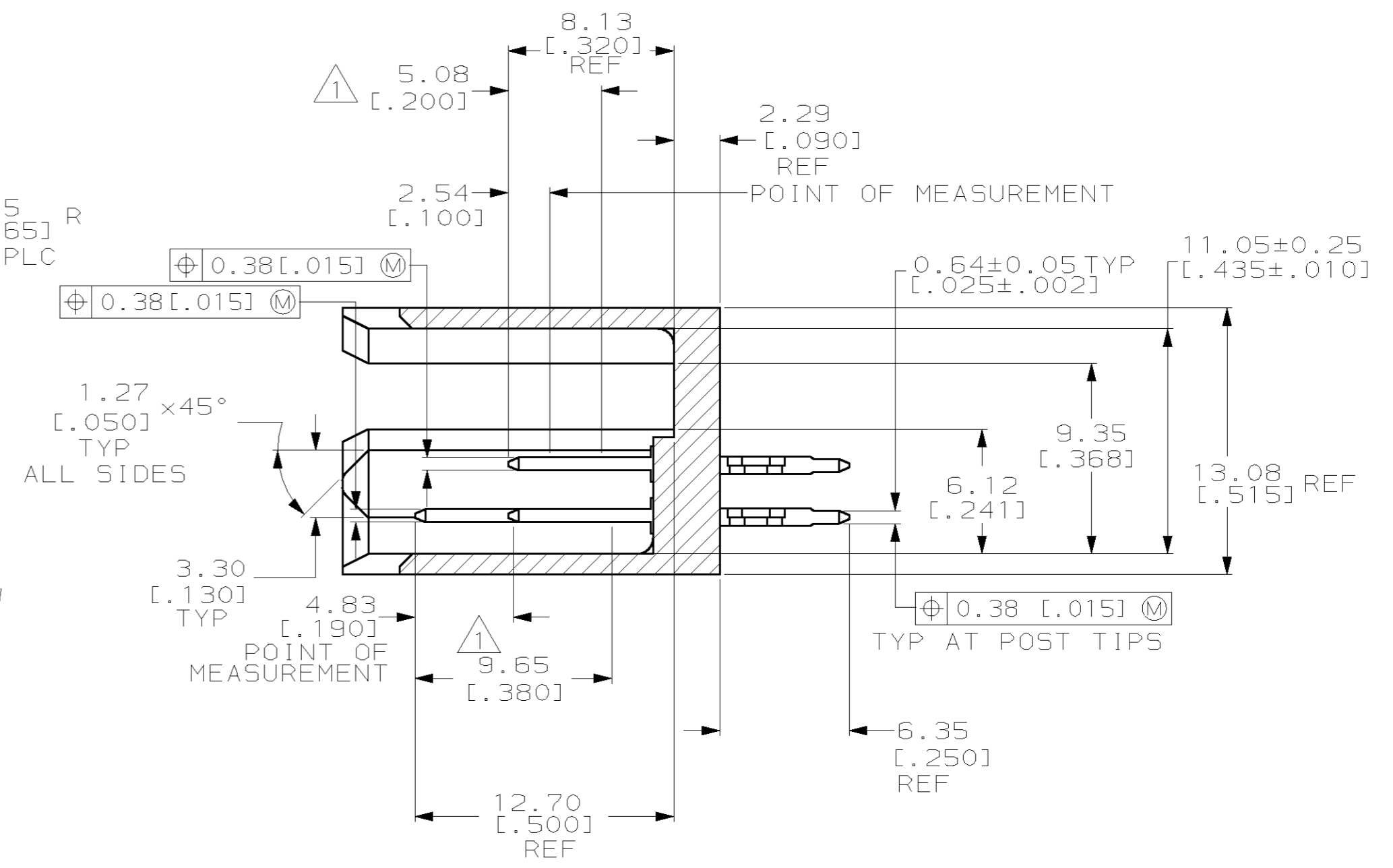
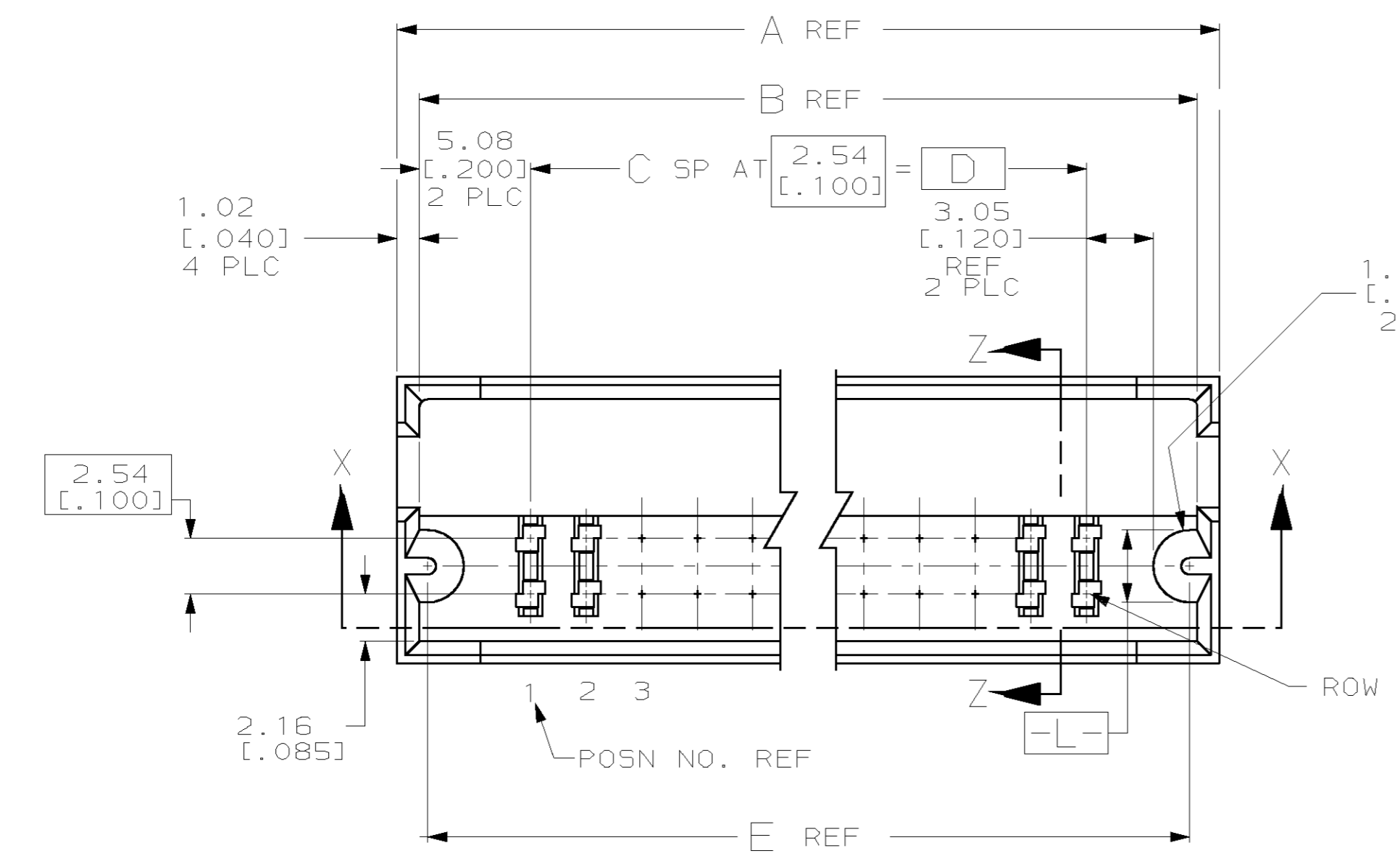

SECTION Z-Z

- ① DUPLEX PLATED: 0.000381[.000015] GOLD ON CONTACT AREA
0.00254-0.00508 [0.00100-.000200] BRIGHT TIN-LEAD ON SOLDER TAILS, ALL OVER 0.00127[.000050]NICKEL.
- ② RECESSED DATE CODE AND CSA LOGO.

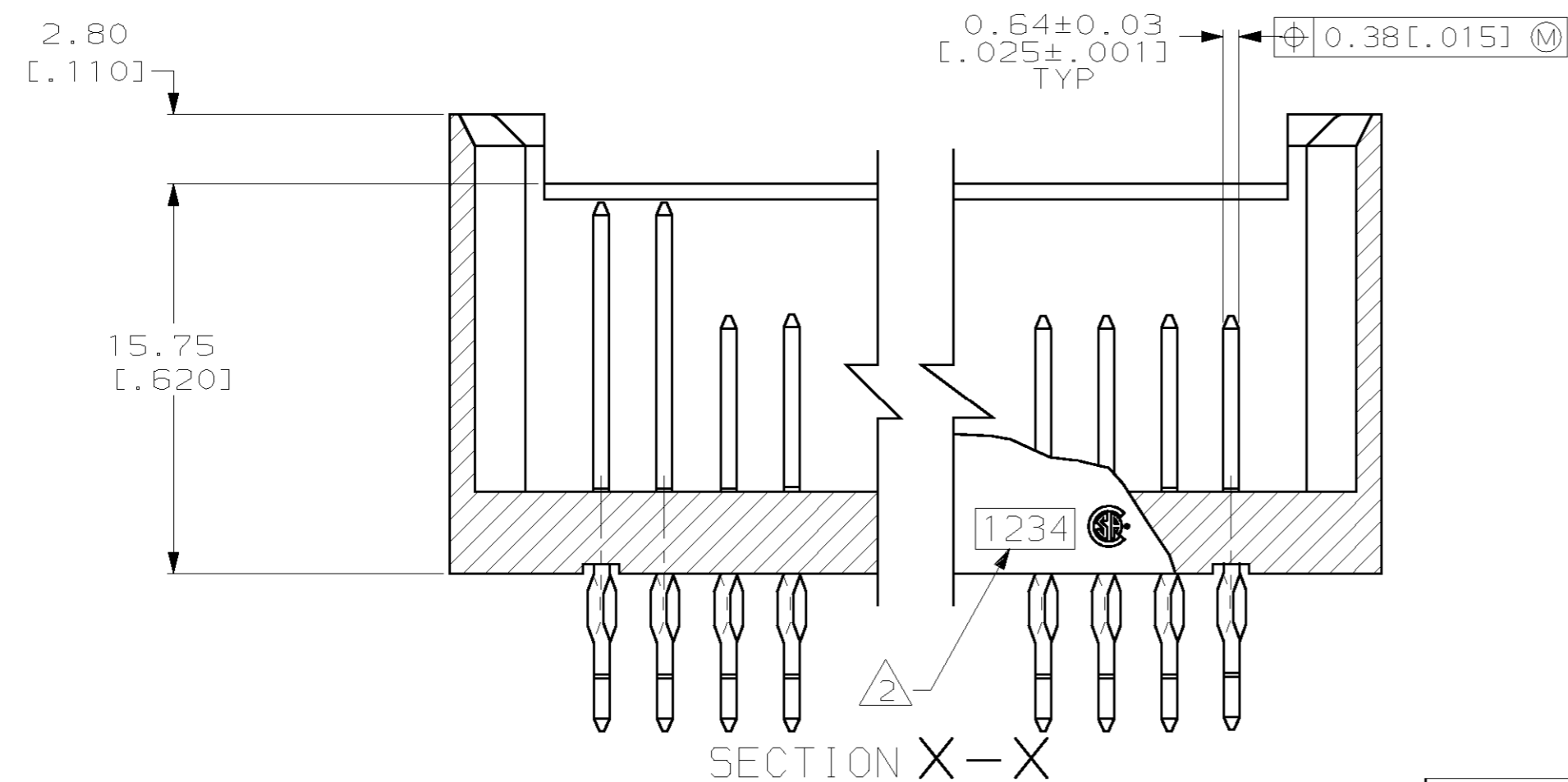

SECTION X-X

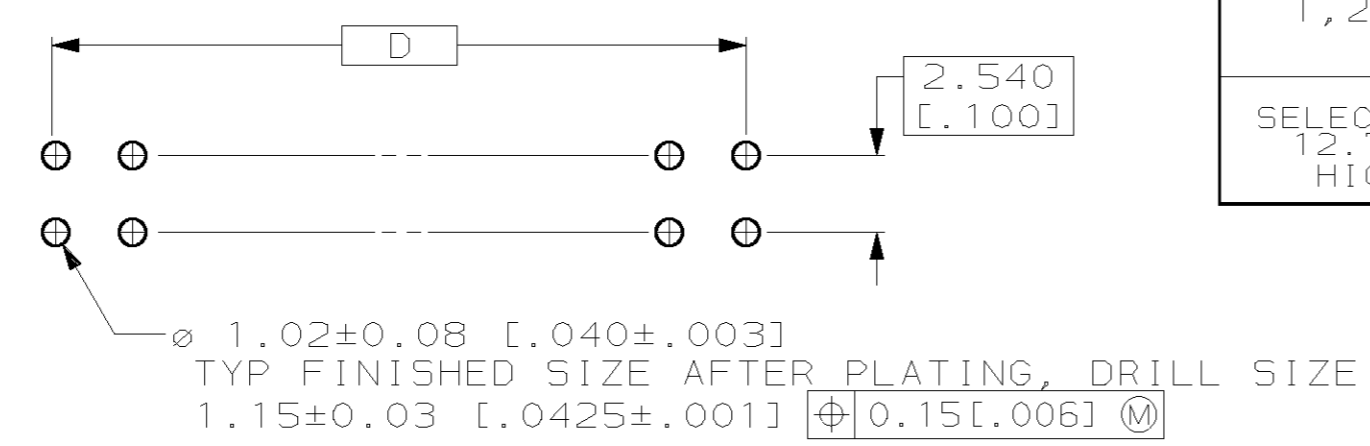

RECOMMENDED HOLE LAYOUT

1,2 ROW W	①	24.64 .970	15.24 [.600]	6	25.40 [1.000]	27.43 [1.080]	14	147294-1
SELECT LOADING 12.70 [.500] HIGH POST	FINISH	E	D	C	B	A	NO. OF POSN	PART NO.

THIS DRAWING IS A CONTROLLED DOCUMENT.		DWN B. HAYMAKER 07AUG98	AMP Incorporated Harrisburg, PA 17105-3608	
DIMENSIONS: MM(INCH)		CHK J. GESFORD 07AUG98	NAME J. GESFORD 07AUG98	
TOLERANCES UNLESS OTHERWISE SPECIFIED:		PRODUCT SPEC		
0 PLC ±-		APPLICATION SPEC		
1 PLC ±-		WEIGHT		
2 PLC ±-		SCALE 4:1		
3 PLC ±0.13(.005)		SHEET 1 OF 1		
4 PLC ±-		REV A		
ANGLES ±-		CUSTOMER DRAWING		
FINISH -		SIZE CAGE CODE DRAWING NO. RESTRICTED TO		
SEE CALLOUT		A2 00779 C- 147294		